

COUNTER INSTALLATION GUIDE

step 1 Register the IT Details



IMPORTANT

IT details must be registered before the installation is carried out onsite.

- 1) Go to www.footfallcounter.com/Register to register a company account (if you don't have any company account yet).
- 2) After login, go to **Administration > Counter Management** page to add site. A **pairing code** will be generated when the site is created.

** SEND PAIRING CODE TO INSTALLER **

Pairing code is unique for each site and is required to connect the counter(s) to FootfallCam Analytics Software.

-  Note: You may create the IT Instructions Work Sheet and send to installer on Configure Site page.

Configure Site

Pairing Code : 1c87bk

Site Name

Site Code

Country

Pairing Code:1c87bk

Company Code: [REDACTED]

Site Name: [REDACTED]

Site Code: [REDACTED]

Copy Only

IT Instructions

step 2 Connect Up the Counter

- 1) Install counter at the **middle of entrance**.
(Please refer to *Part 1: Determine the Correct Counter Position*)
- 2) **Cable installation** from the counter to the router.
(Please refer to *Part 2: Wiring Setup Instructions*)

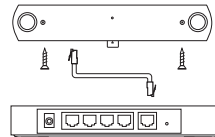

step 3 Configure the Counter

- 1) Login and complete the **Counter Setup Wizard**.
(Please refer to *Part 3: Configuring the Counter*)



Setup Completed. No issues detected

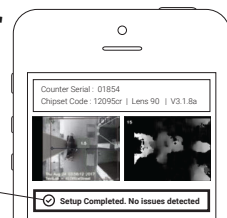

Pre-Installation Checklist

What's In The Box



x1

3D Counter



x1

Power Unit
(Midspan)



x1

1 Meter Cat5e
Network Cable



x2

Screw



x2

Wall Plug



x4

RJ45 Plug

What's Installer Need To Bring

- Cat5e network cable: Cable length depends on distance between the router and the counter
- RJ45 crimp tool: To terminate Cat5e network cable
- Screw drivers and drill
- Ladder: Ladder type depends on the ceiling height

Needs to be Available Onsite

- 1x spare main power socket
- 1x free port on network router

Part 1 Determine the Correct Counter Position

A. Non-Swinging Door

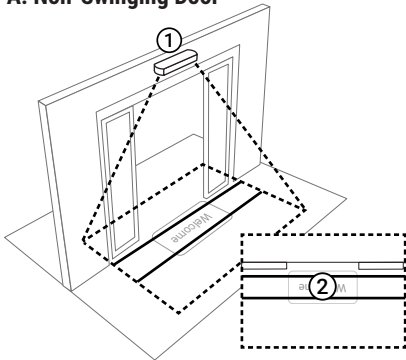

- ① Middle of the entrance
- ② Look perpendicular down

B. Swinging Door

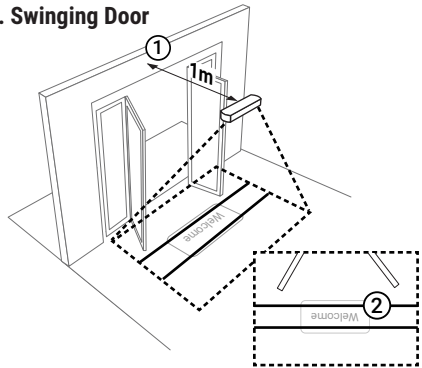

- ① Recommended to install counter 1 meter away from the door
- ② The door swinging path must not be crossing the counting lines



IMPORTANT

Please make sure the counter live view is not blocked by any drop down obstacle (e.g. decorations, exit signage, bulk head, wall, etc.). Otherwise, this may result to the counter not able to count accurately due to the limited tracking zone.

To calculate the clearance distance required between counter and the drop down obstacle, please go to www.footballcam.com/Calculator.

Counter live view is blocked partially by the drop down obstacle.

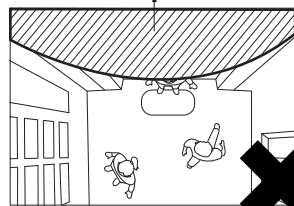

Part 2 Wiring Setup Instructions

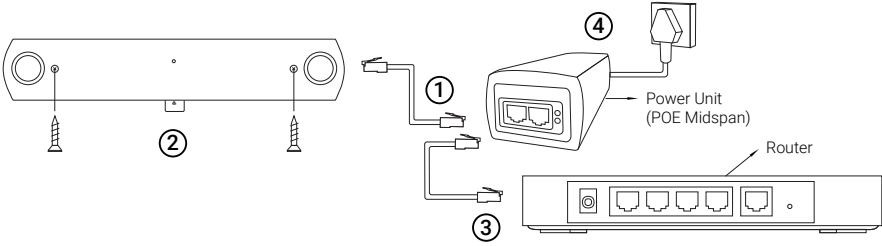

1) CONNECT TO MIDSPAN

Run 1x Cat5e network cable from the counter to the midspan (port labelled "To Counter")

2) CONNECT TO COUNTER

Plug in the counter and secure it onto the ceiling with 2x screws

3) CONNECT TO ROUTER

Run another Cat5e network cable from the router to the midspan (port labelled "To Router")

4) POWER ON

Connect the midspan and turn on power plug.

CRIMP NETWORK CABLE PLUGS

The Color code of ethernet cable **MUST** only follow the T568B Standard to terminate.

Pin	Wire Color	Wire Diagram
1	White - Orange	
2	Orange	
3	White - Green	
4	Blue	
5	White - Blue	
6	Green	
7	White - Brown	
8	Brown	

i Note: Without following the colour code ordering, it may caused cross talk interference.

LED LIGHT INDICATIONS

LED Color	Messages	
No Light	Counter is not powered up Check the power cable and the Cat5e cable connected between counter and midspan.	
Yellow	Network cable is not connected Check the cable connection, re-crimp the cable following the correct color codes (T568B Standard)	
Green	Network or gateway issue(s) Maybe due to no proxy settings, incorrect IP or port is blocked.	
Red	System cannot boot up Reboot the counter by power-off and turn it on again after 5 minutes.	
Blue	Everything OK	

Part 3 Configuring the Counter

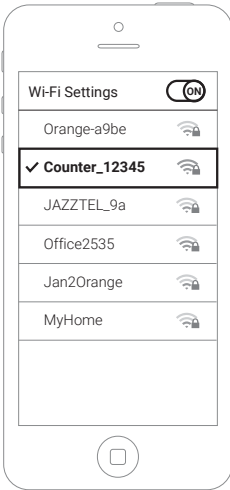

① LOGIN TO COUNTER SETUP WIZARD

Go to the list of available Wi-Fi networks on your mobile device, select the counter SSID e.g. **Counter_12345** and connect with password **counter888**.

Type <http://192.168.4.1> in the browser and login with password **123456**.

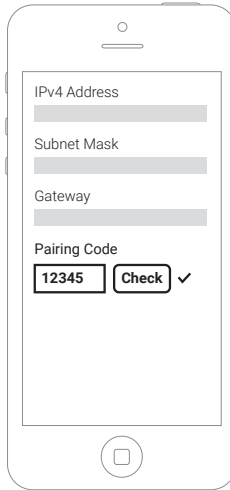

② CONFIGURE THE COUNTER

Input the following details:

-Counter name
(e.g. naming the counters from left to right: SiteName1, SiteName2,etc.) and **ceiling height** (calculate from floor to the mounting height)

-IT details (as stated in the IT Instructions Work Sheet)

-Pairing code (to connect the counter to FootfallCam Analytics Software)

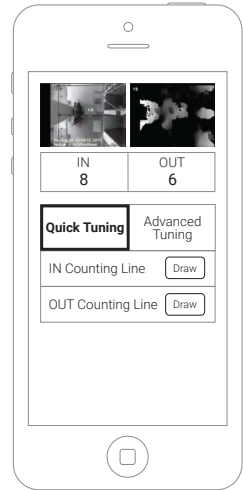

③ QUICK TUNING

Draw the **IN** and **OUT** counting lines.

Perform **walk test** and see if the counter can count accurately.

JOB COMPLETION CHECKLIST



For a successful completion of the installation, please resolve all the issues as highlighted in the Setup Wizard home page until you get the **“Setup Completed”** message.

